



neuson

6001

	Capacity		
	Max. safe load	Front tip	
	Unladen weight	6000 kg	
	Skip - struck	4100 kg	
	- heaped	2400 kg	
	- water level	3200 kg	
	- swing	1000 kg	
		180-212 °	
	Engine		
	Make	Perkins	
	Type	1104C-44 with Powershuttle gearbox	
		4-cyl., water cooled	
	Output (Iso 3046/1)	61,5 (83,6) kw (hp)	
	Revolution	2200 min-1	
	Displacement	4400 ccm	
	Max. Torque	308 Nm	
	Emission	acc. 97/68/EC, step 2	
	Option		
	Make	Perkins (with powershift)	
	Type	1104C-44T turbo charged	
		4-cyl., water cooled	
	Output (Iso 3046/1)	74,5 (100) kw (hp)	
	Revolution	2200 min-1	
	Displacement	4400 ccm	
	Max. Torque	415 Nm	
	Emission	acc. 97/68/EC, step 2	
	Drive characteristics		
	Speed I	0 - 4,5 km/h	
	Speed II	0 - 7,0 km/h	
	Speed III	0 - 14 km/h	
	Speed IV	0 - 27 km/h	
	Steering angle	+/- 32,5 °	
	Oscillation	+/- 13 °	
	Turning radius outside	5200 mm	
	Gradeability	50 %	

	Transmission		
	Final Drive	Torque converter 4 speed power-shuttle transmission, permanent 4 wheel drive, electr. driving direction switch	
	Steering	hydrostatic center-pivot steering (load Sensing)	
	Tyres	405/70-20 14 Ply Traction profile	
	Working brake	foot brake via oil discs in front/rear axle	
	Parking brake	parking brake via dry disc, acting on gearbox	
	Hydraulic System		
	Working pump	gear pump	
	- flowrate		55 l/min
	- oper. press.		220 bar
	Tank capacity		
	Diesel		70 l
	Hydraulic		70 l
	Electric		
	Voltage		12 V
	Battery		105 Ah
	Alternator		40 A
	Starter		2,8 kw
	Noise Emission		
	Noise Level LWA (acc. 2000/14/EC)		105 dB(A)
	Noise Level LPA (acc. 2000/14/EC)		85 dB(A)

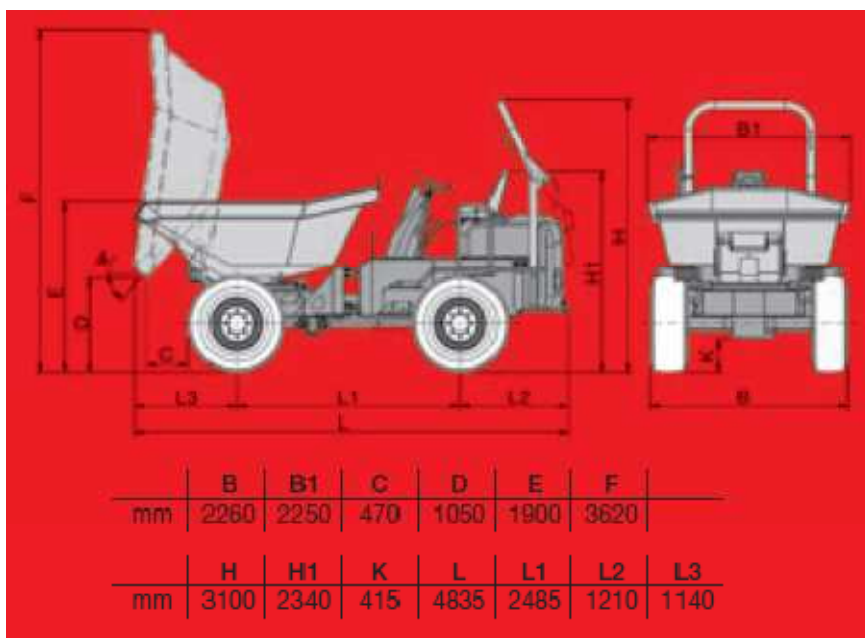

WINNER PLANT

SUSSEX: 01903 230700

SURREY: 01483 456789

EMAIL: SALES@WINNERPLANT.CO.UK